

# Monitek Ultrasonic™

## Oil in Water & Suspended Solids Analyzer

**GALVANIC**  
APPLIED SCIENCES



### Monitek Introduction

- Measures Oil in Water or Suspended Solids
- User-Defined Units (eg. ppm, mg/l, g/l)
- Manufactured & Supported From Massachusetts, USA
- Backed by 40 Years of Experience in Tough Applications

### Rapid Return-On-Investment

- Never Miss Unexpected Break-Through
- Meet Environmental Regulations
- Optimize Process Control

### Measurement Certainty

- CRN Sensor Rated to 150°C & 260 psi
- Accurate in Dirty, Dark Samples
- Customized Materials of Construction
- Zero Downtime Sensor Removal
- Up to 100 m Cable

### Key Applications

- Oil & Water Separators
- Filter Break-Through

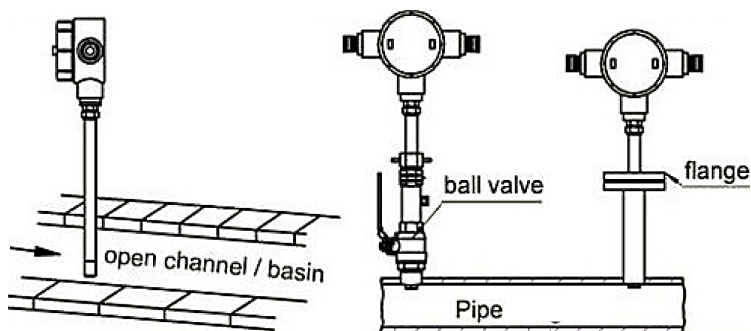

## Monitek Ultrasonic™

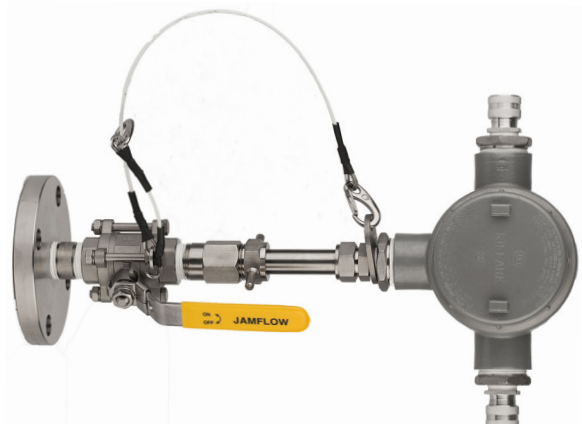

## Detects Pepper in Black Coffee !



## Handles Ex-Proof Outdoor Installations



## Explosion-Proof Sensor



## Pipe Adapter Simplifies Installation

